

Combat[®]

High-Flow Cabinet Heaters



- Ideal for use in large, energy efficient buildings with high air flow and lower heat requirements
- Wide range of heat output and airflow combinations
- Flexibility for system designers, allowing connection to high resistance elements such as cooling coils
- Design flexibility with floor standing, horizontal mount or external site installation
- High efficiency ECA approval - all versions available

+44 (0)121 506 7700

www.rg-inc.com



Authorised User No. 00184



0063

Technical Data - HF30 Range

Model		HF30v4	HF30v5	HF30v6
Maximum Heat Input - Gross	[kW]	103.0	103.0	103.0
	[Btu/h] x [1000]	351,436	351,436	351,436
Maximum Heat Output	[kW]	86.2	86.2	86.2
	[Btu/h] x [1000]	294,225	294,225	294,225
Reduced Gross Input (High/Low & Modulating Burners Only)	[kW]	63.3	63.3	63.3
	[Btu/h] x [1000]	215,809	215,809	215,809
Reduced Output (High/Low & Modulating Burners Only)	[kW]	53	53	53
	[Btu/h] x [1000]	180,836	180,836	180,836
Maximum Gas Rate Natural (G20)	[m ³ /h]	9.9	9.9	9.9
	[ft ³ /h]	349.6	349.6	349.6
Minimum Gas Rate Natural (G20) (High/Low & Modulating Burners Only)	[m ³ /h]	6.0	6.0	6.0
	[ft ³ /h]	212	212	212
Inlet Pressure Natural Gas (G20)	[mbar]	20	20	20
		(Minimum: 17; Maximum: 25)		
Gas Connection	[in]	R ³ / ₄	R ³ / ₄	R ³ / ₄
Oil: Heat Input - Gross	[kW]	109.7	109.7	109.7
	[Btu/h] x [1000]	374,277	374,277	374,277
Oil: Heat Output	[kW]	87.9	87.9	87.9
	[Btu/h] x [1000]	300,000	300,000	300,000
Oil Consumption	[L/h]	10.4	10.4	10.4
	[gal/h]	2.3	2.3	2.3
Air Flow		See Graph Below		
Maximum Motor Start Current	[A]	27	40	40
Maximum Motor Running Current	[A]	5.0	8.4	8.4
Motor Size	[kW]	2.2	4.0	4.0
Electrical Supply		400 V / 50 Hz / 3 Ø		

For ducted application (spigot top plate supplied).

Notes: Heater inputs are maximum for each version, at minimum air flow on graph below. LPG data available on request.

Graph of Air Flow v Static Pressure: High Flow 30 Range

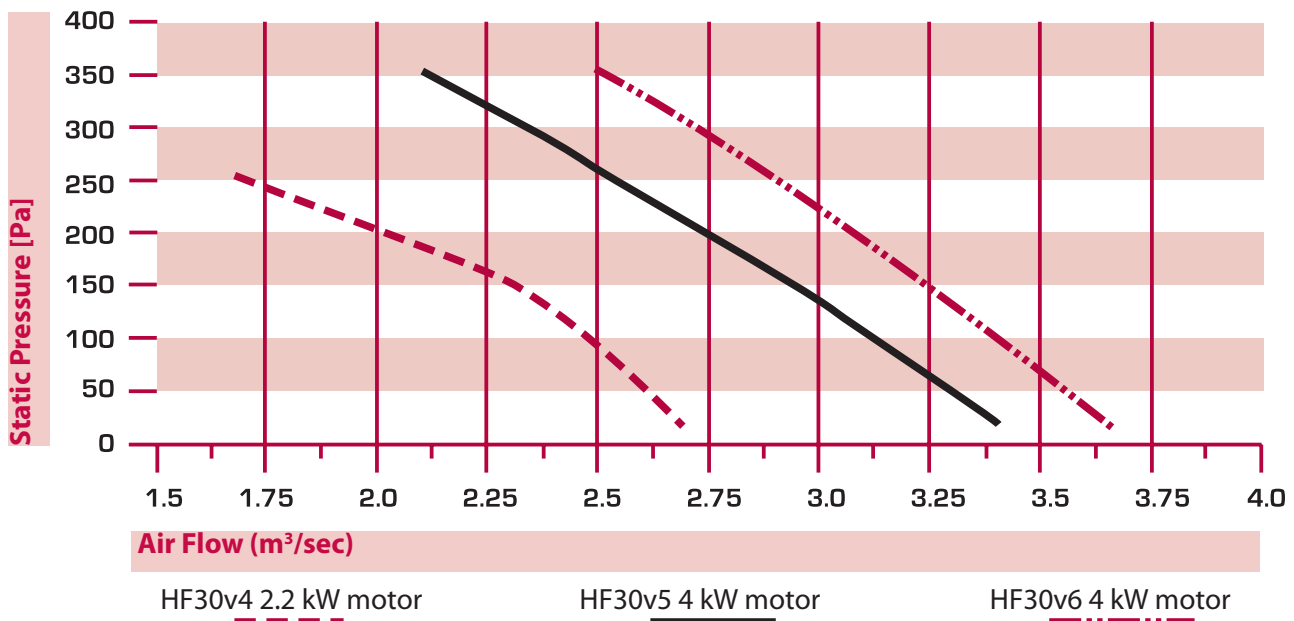

Technical Data - HF40 Range

Model		HF40v1	HF40v2	HF40v3
Maximum Heat Input - Gross	[kW]	144.7	144.7	144.7
	[Btu/h] x [1000]	493,546	493,546	493,546
Maximum Heat Output	[kW]	117.6	117.6	117.6
	[Btu/h] x [1000]	401,378	401,378	401,378
Reduced Gross Input (High/Low & Modulating Burners Only)	[kW]	86.4	86.4	86.4
	[Btu/h] x [1000]	294,626	294,626	294,626
Reduced Output (High/Low & Modulating Burners Only)	[kW]	70.2	70.2	70.2
	[Btu/h] x [1000]	239,659	239,659	239,659
Maximum Gas Rate Natural (G20)	[m ³ /h]	13.9	13.9	13.9
	[ft ³ /h]	491	491	491
Minimum Gas Rate Natural (G20) (High/Low & Modulating Burners Only)	[m ³ /h]	8.3	8.3	8.3
	[ft ³ /h]	293	293	293
Inlet Pressure Natural Gas (G20)	[mbar]	293	293	293
		(Minimum: 17; Maximum: 25)		
Gas Connection	[in]	R ³ / ₄	R ³ / ₄	R ³ / ₄
Oil: Heat Input - Gross	[kW]	146.2	146.2	146.2
	[Btu/h] x [1000]	498,786	498,786	498,786
Oil: Heat Output	[kW]	117.2	117.2	117.2
	[Btu/h] x [1000]	400,000	400,000	400,000
Oil Consumption	[L/h]	13.8	13.8	13.8
	[gal/h]	3.0	3.0	3.0
Air Flow		See Graph Below		
Maximum Motor Start Current	[A]	20.0	32.0	35.0
Maximum Motor Running Current	[A]	5.4	9.4	11.5
Motor Size	[kW]	2.2	4.0	4.0
Electrical Supply		400 V / 50 Hz / 3 Ø		

For ducted application (spigot top plate supplied).

Notes: Heater inputs are maximum for each version, at minimum air flow on graph below. LPG data available on request.

Graph of Air Flow v Static Pressure: High Flow 40 Range

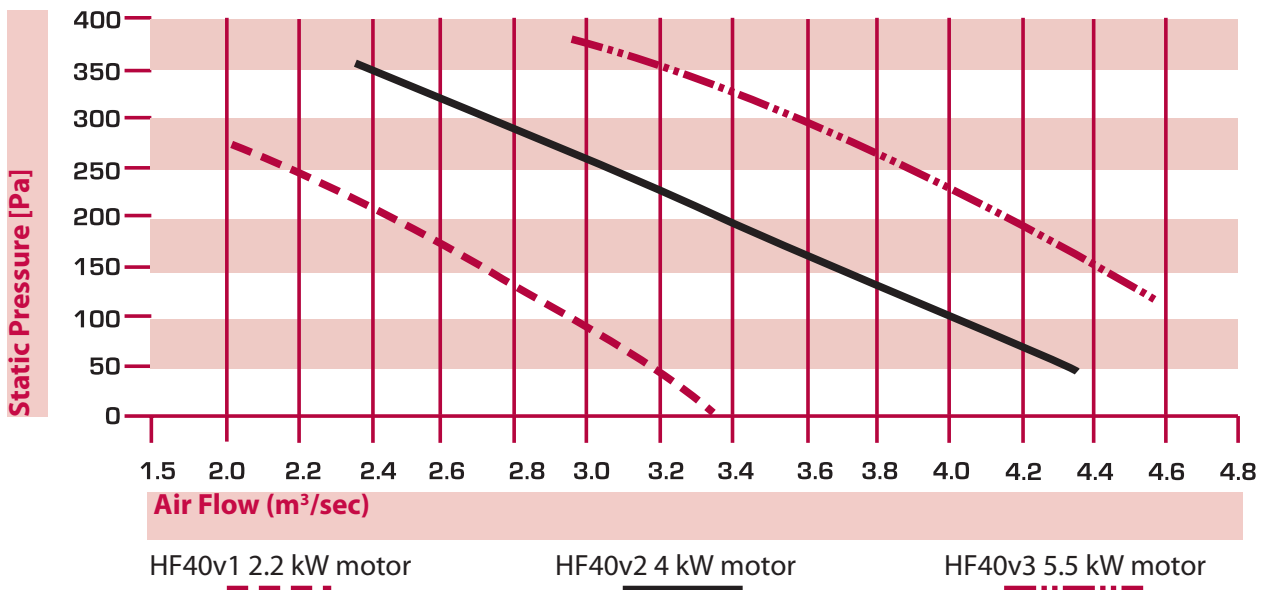

Technical Data - HF50 Range

Model		HF50v1	HF50v2	HF50v3	HF50v4
Maximum Heat Input - Gross	[kW]	182.1	182.1	182.1	182.1
	[Btu/h] x [1000]	621,155	621,155	621,155	621,155
Maximum Heat Output	[kW]	144.8	144.8	144.8	144.8
	[Btu/h] x [1000]	494,100	494,100	494,100	494,100
Reduced Gross Input (High/Low & Modulating Burners Only)	[kW]	108.9	108.9	108.9	108.9
	[Btu/h] x [1000]	371,567	371,567	371,567	371,567
Reduced Output (High/Low & Modulating Burners Only)	[kW]	89.6	89.6	89.6	89.6
	[Btu/h] x [1000]	305,698	305,698	305,698	305,698
Maximum Gas Rate Natural (G20)	[m ³ /h]	17.5	17.5	17.5	17.5
	[ft ³ /h]	618	618	618	618
Minimum Gas Rate Natural (G20) (High/Low & Modulating Burners Only)	[m ³ /h]	10.5	10.5	10.5	10.5
	[ft ³ /h]	371	371	371	371
Inlet Pressure Natural Gas (G20)	[mbar]	20	20	20	20
Gas Connection	[in]	(Minimum: 17; Maximum: 25) R 1¼			
Oil: Heat Input - Gross	[kW]	183.2	183.2	183.2	183.2
	[Btu/h] x [1000]	625,000	625,000	625,000	625,000
Oil: Heat Output	[kW]	146.5	146.5	146.5	146.5
	[Btu/h] x [1000]	500,000	500,000	500,000	500,000
Oil Consumption	[L/h]	17.3	17.3	17.3	17.3
	[gal/h]	3.8	3.8	3.8	3.8
Air Flow		See Graph Below			
Maximum Motor Start Current	[A]	20.0	35.0	37.5	37.5
Maximum Motor Running Current	[A]	8.2	11.5	16.5	18
Motor Size	[kW]	4.0	5.5	7.5	7.5
Electrical Supply		400 V / 50 Hz / 3 Ø			

For ducted application (spigot top plate supplied).

Notes: Heater inputs are maximum for each version, at minimum air flow on graph below. LPG data available on request.

Graph of Air Flow v Static Pressure: High Flow 50 Range

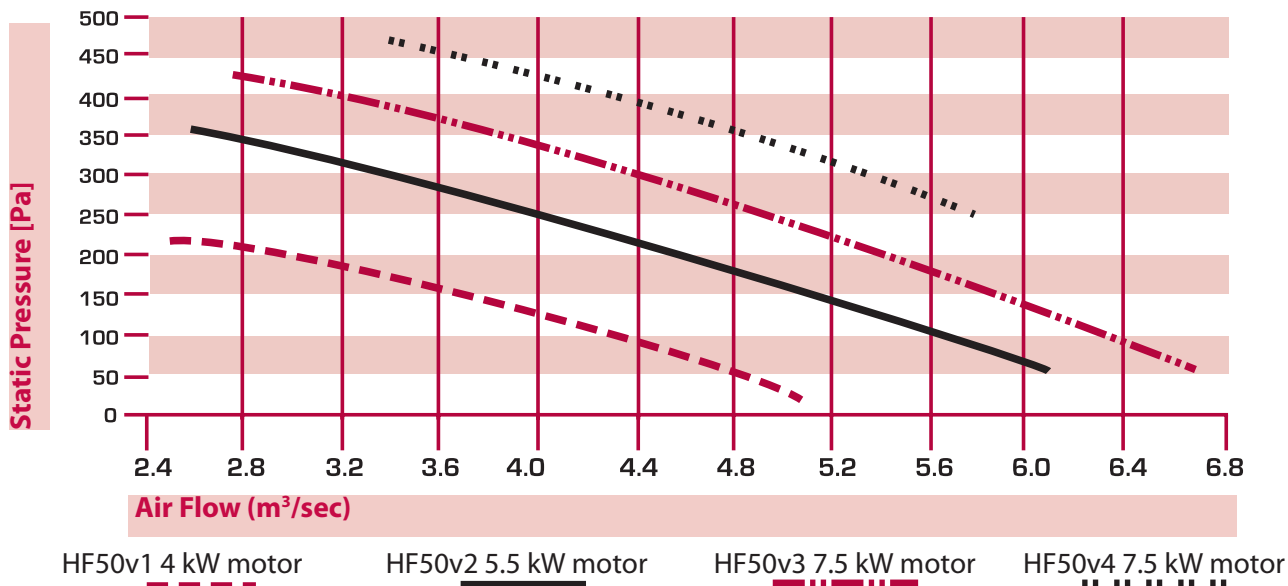

Controls

Combat® High-Flow cabinet heaters are designed to be operated with external controls and are fitted with electrical terminals to accommodate these.

Burner Options

COMBAT® High-Flow cabinet heaters are fitted On/Off burners as standard. High/Low burners are available as an option on all models, and a fully modulating burner is available as an option on all Natural Gas and LPG fired models.

Inlet & Outlet Ducts

Where there is a need for the heater to be connected to fresh air or air from an adjacent area for its intake of distribution air, inlet duct connections can be provided.

Note: Supply air inlet connections can be made from either side, but not from the front or rear of the heater. When employing an inlet duct arrangement, there must be adequate provision for the supply of combustion air. Please contact Roberts-Gordon for advice. High-Flow cabinet heaters are fitted with an air outlet spigot fitted as standard.

Fuel

Combat® High-Flow cabinet heaters are designed for use on either: Natural Gas (G20), Propane (G31), Butane (G30), or Oil (Class D fuel oil to BS2869 (35 sec Redwood No .1).

Oil Connection Kit

For all oil fired heaters, an oil line connection kit comprising of a gate valve, spring operated fire valve, oil filter and connecting nipples are required for installation on site.



COMBAT® High-Flow Cabinet Heaters are high efficiency heaters and are listed on the Enhanced Capital Allowance Scheme 'Energy Technology Product List'. The ETL symbol is a UK registered certification mark of the carbon trust.

Important Notice

The equipment described in this Data Sheet is suitable for most commercial and industrial heating applications. However, in certain environments, particularly where there is a chlorinated atmosphere (e.g. near degreasing plant or other solvent processes), or a particularly dusty atmosphere, specialist advice should be sought at the design stage. Please consult Roberts-Gordon.

Roberts-Gordon reserves the right to alter product specification details without notice.

Installation Code and Annual Inspections:

All installations and service of ROBERTS GORDON® equipment must be performed by a contractor qualified in the installation and service of equipment sold and supplied by Roberts-Gordon and conform to all requirements set forth in the ROBERTS GORDON® manuals and all applicable governmental authorities pertaining to the installation, service and operation of the equipment. To help facilitate optimum performance and safety, Roberts-Gordon recommends that a qualified contractor conduct, at a minimum, annual inspections of your ROBERTS GORDON® equipment and perform service where necessary, using only replacement parts sold and supplied by Roberts-Gordon.

Further Information: Applications, engineering and detailed guidance on systems design, installation and equipment performance is available through ROBERTS GORDON® representatives. Please contact us for any further information you may require, including the Installation, Operation and Service Manual.

This product is not for residential use.

This document is intended to assist licensed professionals in the exercise of their professional judgement.

Dimension Data

All dimensions shown in mm.

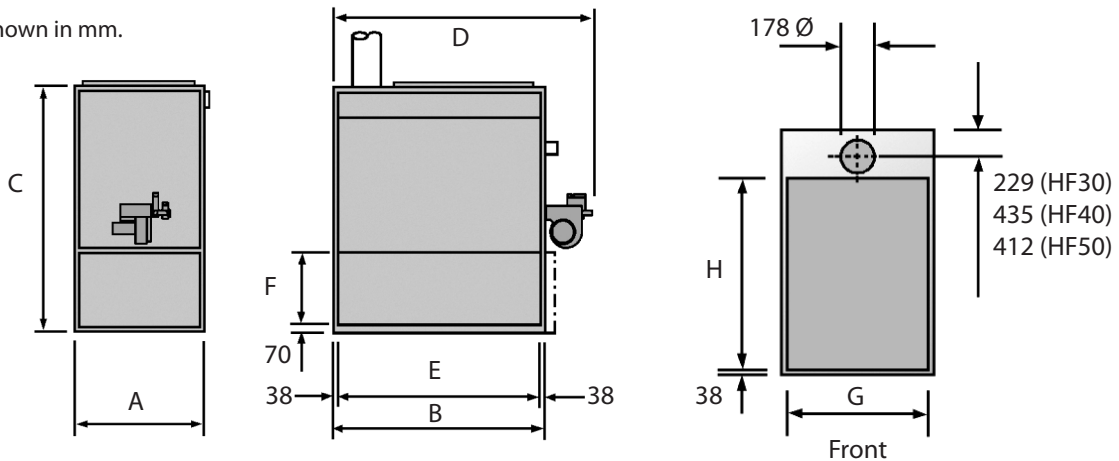

Model		HF30	HF30	HF30	HF40	HF40	HF40	HF50	HF50	HF50	HF50
		v4	v5	v6	v1	v2	v3	v1	v2	v3	v4
Cabinet Model		50	50	50	60	60	60	100	100	100	100
'A' Width	[mm]	857	857	857	1016	1016	1016	1016	1016	1016	1016
'B' Depth Cabinet Only	[mm]	1016	1016	1016	1676	1676	1676	1994	1994	1994	1994
'C' Height Cabinet Only	[mm]	1930	1930	1930	1930	1930	1930	1930	1930	1930	1930
'D' Depth Overall	[mm]	1507	1507	1507	2388	2388	2388	2706	2706	2706	2706
'E' Inlet Duct Dimension - Depth	[mm]	940	940	940	1600	1600	1600	1918	1918	1918	1918
'F' Inlet Duct Dimension - Height	[mm]	559	559	559	560	559	559	559	559	559	559
'G' Outlet Duct Dimension - Width	[mm]	781	781	781	940	940	940	940	940	940	940
'H' Outlet Duct Dimension - Depth	[mm]	610	610	610	1030	1030	1030	1350	1350	1350	1350
Weight	[kg]	300	300	300	400	400	400	520	520	520	520
Flue Diameter	[mm]	178	178	178	178	178	178	178	178	178	178

Heater Clearances to Combustibles (mm)

To Side of Heater	To Rear of Heater	To Front of Heater	For Air Distribution
600	600	2000	4000

Note: The pressure relief door for HF30 range is located on the rear of the heater. Dimension data for External models is available on request. All heaters must be connected to a suitable flue system.

Roberts-Gordon Europe Limited

Unit A, Kings Hill Business Park
 Darlaston Road, Wednesbury
 West Midlands, WS10 7SH UK
 Telephone: +44 (0)121 506 7700
 Fax: +44 (0)121 506 7701
 Service Telephone: +44 (0)121 506 7709
 Service Fax: +44 (0)121 506 7702
 E-mail: uksales@rg-inc.com
 E-mail: export@rg-inc.com
www.rog-inc.com